

ROBOTICS

# Application manual

## DeviceNet Anybus Slave



Trace back information:  
Workspace 19D version a3  
Checked in 2019-12-04  
Skribenta version 5.3.033

**Application manual**  
**DeviceNet Anybus Slave**

RobotWare 6.10.01

Document ID: 3HAC050993-001

Revision: C

The information in this manual is subject to change without notice and should not be construed as a commitment by ABB. ABB assumes no responsibility for any errors that may appear in this manual.

Except as may be expressly stated anywhere in this manual, nothing herein shall be construed as any kind of guarantee or warranty by ABB for losses, damages to persons or property, fitness for a specific purpose or the like.

In no event shall ABB be liable for incidental or consequential damages arising from use of this manual and products described herein.

This manual and parts thereof must not be reproduced or copied without ABB's written permission.

Keep for future reference.

Additional copies of this manual may be obtained from ABB.

Original instructions.

© Copyright 2015-2019 ABB. All rights reserved.  
Specifications subject to change without notice.

# Table of contents

Overview of this manual .....	7
Product documentation .....	9
Safety .....	11
Network security .....	12
Terminology .....	13
<b>1 Introduction</b> .....	<b>15</b>
1.1 What is DeviceNet? .....	15
1.2 The DeviceNet anybus slave for IRC5 .....	16
<b>2 Hardware overview</b> .....	<b>19</b>
2.1 Main computer DSQC1000 .....	19
2.2 Cables and connections .....	22
2.2.1 Shield grounding and power .....	22
2.2.2 Termination resistors .....	24
2.2.3 Cabling .....	25
2.2.4 Selecting cables .....	26
2.2.5 Repeaters .....	27
<b>3 Software overview</b> .....	<b>29</b>
3.1 Information about the anybus slave device .....	29
<b>4 Configuring the anybus slave device</b> .....	<b>31</b>
4.1 Recommended working procedure .....	31
4.2 Configuring the anybus slave device .....	32
4.3 Configuring the external master .....	34
4.4 Communication between two IRC5 controllers .....	35
<b>5 System parameters</b> .....	<b>37</b>
5.1 Introduction .....	37
5.1.1 DeviceNet system parameters .....	38
5.2 Type Industrial Network .....	39
5.2.1 Address .....	39
5.3 Type DeviceNet Internal Anybus Device .....	40
5.3.1 Connection Input Size .....	40
5.3.2 Connection Output Size .....	41
<b>Index</b> .....	<b>43</b>

**This page is intentionally left blank**

# Overview of this manual

## About this manual

This manual describes the option DeviceNet Anybus Slave and contains instructions for the configuration.

## Usage

This manual should be used during installation and configuration of the DeviceNet anybus slave and upgrading of the option DeviceNet Anybus Slave.

## Who should read this manual?

This manual is intended for:

- Personnel responsible for installations and configurations of industrial network hardware/software
- Personnel responsible for I/O system configuration
- System integrators

## Prerequisites

The reader should have the required knowledge of:

- Mechanical installation work
- Electrical installation work

## References

### Document references

References	Document ID
<i>Application manual - DeviceNet Master/Slave</i>	3HAC050992-001
<i>Operating manual - IRC5 with FlexPendant</i>	3HAC050941-001
<i>Operating manual - RobotStudio</i>	3HAC032104-001
<i>Product manual - IRC5</i>	3HAC047136-001
<i>Product specification - Controller IRC5</i>	3HAC047400-001
<i>Technical reference manual - System parameters</i>	3HAC050948-001

### Other references

References	Description
<a href="http://www.odva.org">www.odva.org</a>	The web site of ODVA (Open DeviceNet Vendor Association).
The DeviceNet Specification	ODVA Specification

## Revisions

Revision	Description
-	First edition. Released with RobotWare 6.0.

*Continues on next page*

## Overview of this manual

---

*Continued*

Revision	Description
A	Released with RobotWare 6.01. <ul style="list-style-type: none"><li>• Minor corrections.</li><li>• System parameter <i>Connection</i> removed from <i>Industrial Network</i>.</li></ul>
B	Released with RobotWare 6.02. <ul style="list-style-type: none"><li>• Updated the path to the template files, see <a href="#">Template I/O configuration file on page 30</a>.</li></ul>
C	Released with RobotWare 6.10.01. <ul style="list-style-type: none"><li>• Cfg name removed from entire manual.</li></ul>



# Product documentation

---

## Categories for user documentation from ABB Robotics

The user documentation from ABB Robotics is divided into a number of categories. This listing is based on the type of information in the documents, regardless of whether the products are standard or optional.

All documents can be found via myABB Business Portal, [www.myportal.abb.com](http://www.myportal.abb.com).

---

## Product manuals

Manipulators, controllers, DressPack/SpotPack, and most other hardware is delivered with a **Product manual** that generally contains:

- Safety information.
  - Installation and commissioning (descriptions of mechanical installation or electrical connections).
  - Maintenance (descriptions of all required preventive maintenance procedures including intervals and expected life time of parts).
  - Repair (descriptions of all recommended repair procedures including spare parts).
  - Calibration.
  - Decommissioning.
  - Reference information (safety standards, unit conversions, screw joints, lists of tools).
  - Spare parts list with corresponding figures (or references to separate spare parts lists).
  - References to circuit diagrams.
- 

## Technical reference manuals

The technical reference manuals describe reference information for robotics products, for example lubrication, the RAPID language, and system parameters.

---

## Application manuals

Specific applications (for example software or hardware options) are described in **Application manuals**. An application manual can describe one or several applications.

An application manual generally contains information about:

- The purpose of the application (what it does and when it is useful).
- What is included (for example cables, I/O boards, RAPID instructions, system parameters, software).
- How to install included or required hardware.
- How to use the application.
- Examples of how to use the application.

*Continues on next page*

---

### Operating manuals

The operating manuals describe hands-on handling of the products. The manuals are aimed at those having first-hand operational contact with the product, that is production cell operators, programmers, and troubleshooters.

---

# Safety

---

## Safety of personnel

When working inside the robot controller it is necessary to be aware of voltage-related risks.

A danger of high voltage is associated with the following parts:

- Devices inside the controller, for example I/O devices, can be supplied with power from an external source.
- The mains supply/mains switch.
- The power unit.
- The power supply unit for the computer system (230 VAC).
- The rectifier unit (400-480 VAC and 700 VDC). Capacitors!
- The drive unit (700 VDC).
- The service outlets (115/230 VAC).
- The power supply unit for tools, or special power supply units for the machining process.
- The external voltage connected to the controller remains live even when the robot is disconnected from the mains.
- Additional connections.

Therefore, it is important that all safety regulations are followed when doing mechanical and electrical installation work.

---

## Safety regulations

Before beginning mechanical and/or electrical installations, ensure you are familiar with the safety regulations described in *Operating manual - General safety information*<sup>1</sup>.

<sup>1</sup> This manual contains all safety instructions from the product manuals for the manipulators and the controllers.

# Network security

---

### Network security

This product is designed to be connected to and to communicate information and data via a network interface. It is your sole responsibility to provide, and continuously ensure, a secure connection between the product and to your network or any other network (as the case may be).

You shall establish and maintain any appropriate measures (such as, but not limited to, the installation of firewalls, application of authentication measures, encryption of data, installation of anti-virus programs, etc) to protect the product, the network, its system and the interface against any kind of security breaches, unauthorized access, interference, intrusion, leakage and/or theft of data or information. ABB Ltd and its entities are not liable for damages and/or losses related to such security breaches, any unauthorized access, interference, intrusion, leakage and/or theft of data or information.

# Terminology

## Terms

Term	Explanation
CIP	Common Industrial Protocol. Protocol that DeviceNet and EtherNet/IP are based on.
Client	See term <i>Master</i> . Some documents use the term <i>client</i> , whereas the ABB documentation use the term <i>Master</i> for DeviceNet industrial network.
EDS	Electronic Data Sheet. EDS files contain the configuration details relevant to CIP devices.
Explicit Messages	An explicit message is a request or response oriented communication with other devices. These messages are mostly configuration data.
Internal Anybus Slave Device	A built-in device in the robot controller.
Master	Controls other devices (nodes) in a DeviceNet network.
ODVA	Open DeviceNet Vendor Association. Organization for networks built on CIP, for example DeviceNet and EtherNet/IP.
Server	See term <i>Slave</i> . Some documents use the term <i>server</i> , whereas the ABB documentation use the term <i>slave</i> for DeviceNet network.
Slave	I/O device that is controlled by a master in a DeviceNet network.

**This page is intentionally left blank**

---

# 1 Introduction

## 1.1 What is DeviceNet?

---

### General

DeviceNet is one of the world's leading device-level networks for industrial automation. DeviceNet offers robust and efficient data handling because it is based on Producer/Consumer technology. This modern communications model offers key capabilities that allow the user to determine effectively what information is needed and when.

Users are also benefitted from the ODVA's strong conformance testing policies, which ensure that products are interoperable. As a result, users can mix-and-match products from a variety of suppliers and integrate them seamlessly.

---

### DeviceNet standardization

DeviceNet is standardized according to the International standard IEC 62026, and DeviceNet devices are certified by ODVA for interoperability and conformance.

---

### Electronic Data Sheet file

The configuration process is based on EDS files (Electronic Data Sheet) which are required for each DeviceNet device. EDS files are provided by the device manufacturers and contain electronic descriptions of all relevant communication parameters and objects of the DeviceNet device.

The EDS file for the DeviceNet Anybus Slave, DSQC1004 is part of the RobotWare distribution.

# 1 Introduction

## 1.2 The DeviceNet anybus slave for IRC5

### 1.2 The DeviceNet anybus slave for IRC5

#### General

The DeviceNet anybus slave for IRC5 is inserted into an expansion board on top of the main computer unit in the robot controller.

The DeviceNet anybus slave, DSQC1004, requires the main computer DSQC1000.

#### Options

With option *DeviceNet Anybus Slave*, the IRC5 controller can act as a slave on the DeviceNet network.



#### Note

If DeviceNet master functionality is required, then the option *DeviceNet Master/Slave* must be used.

For more information see *Application manual - DeviceNet Master/Slave*.

#### Illustration, example

The following figure illustrates an overview of the hardware.

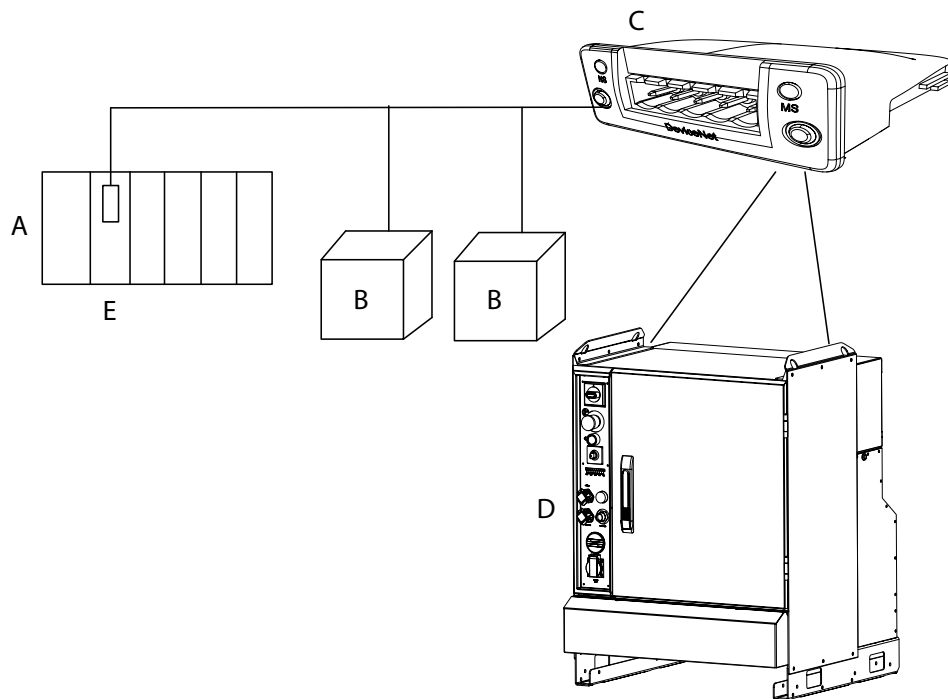

xx1300000225

A	PLC
B	General DeviceNet I/O device
C	DeviceNet anybus slave, DSQC1004
D	IRC5 controller
E	DeviceNet Master/Scanner

Continues on next page



### Specification overview

Item	Specification
Industrial Network	DeviceNet
Specification revision	DeviceNet Specification Edition 2.0
Data rate	125, 250, 500 kbps, Automatic Baudrate Detection
Connection type	Explicit messaging, Bit-strobed I/O, Change-of-state/Cyclic I/O, Polled I/O
Connection size	Maximum 64 input bytes and 64 output bytes

**This page is intentionally left blank**

## 2 Hardware overview

### 2.1 Main computer DSQC1000

#### Connections

The I/O network is connected to the DeviceNet anybus slave, DSQC1004, on the main computer.

The following figure illustrates the location of the anybus slave in the main computer unit.

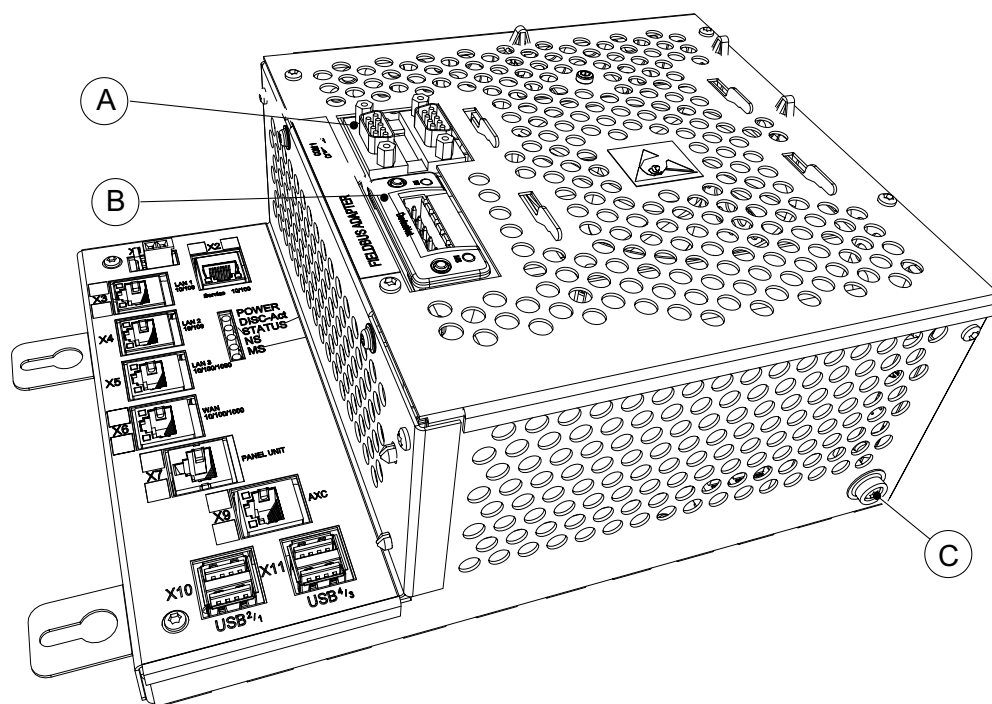

xx1300000676

	Description	Designation	Article number
A	Anybus Slave / RS232 expansion board	DSQC1003	3HAC046408-001
B	DeviceNet anybus slave	DSQC1004	3HAC045973-002
C	Ground connection for ESD bracelet		

#### Installation of the anybus slave

For information on how to install and replace the anybus slave, see *Product manual - IRC5*.

*Continues on next page*

## 2 Hardware overview

### 2.1 Main computer DSQC1000

Continued

#### Illustration, DeviceNet anybus slave DSQC1004

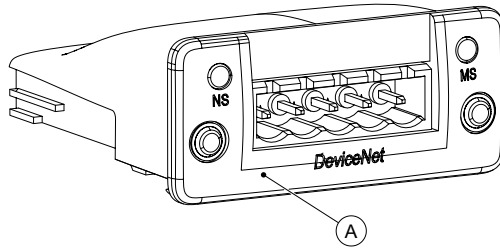

xx1300000671

A	DeviceNet anybus slave
NS	Network status LED
MS	Module status LED

#### LEDs

This section describes the LEDs of the DeviceNet anybus slave.

##### Network Status (NS) LED



#### Note

A test sequence is performed on this LED during start of the device.

LED state	Description
Off	Not online / No power
Green	Online, one or more connections are established
Flashing Green (1 Hz)	Online, no connections established
Red	Critical link failure
Flashing Red (1 Hz)	One or more connections timed out
Alternating Red/Green	Self test

##### Module Status (MS) LED



#### Note

A test sequence is performed on this LED during start of the slave device.

LED state	Description
Off	No power
Green	Operating in normal condition
Flashing Green (1 Hz)	Missing or incomplete configuration, device needs commissioning
Red	Unrecoverable fault(s)
Flashing Red (1 Hz)	Recoverable fault(s)
Alternating Red/Green	Self test

Continues on next page



#### Note

If the DeviceNet anybus slave device loses connection with the master, the configured input signals are cleared (reset to zero).

When the connection is re-established, the master updates the input signals.

#### DeviceNet anybus slave connector

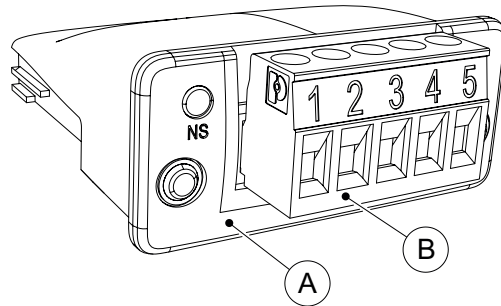

xx130000677

A	DeviceNet anybus slave
B	Pin Connector

The following table describes the connections to the DeviceNet Anybus Slave connector.

Signal name	I/O pin	Wire color	Function
V-	1	black	DeviceNet network negative power (0 V)
CANL	2	blue	DeviceNet communication network terminal (low)
Shield	3	bare	Network cable shield
CANH	4	white	DeviceNet communication network terminal (high)
V+	5	red	DeviceNet network positive power (24 V DC)

## 2 Hardware overview

### 2.2.1 Shield grounding and power

## 2.2 Cables and connections

### 2.2.1 Shield grounding and power

#### General

The DeviceNet shield and V- should be interconnected and grounded at only one place in the DeviceNet network. For more advanced connections with several power supplies refer to the *DeviceNet Specification*, see [References on page 7](#).

#### Power supply

Some I/O devices may also require separate power supply for the I/O signals.

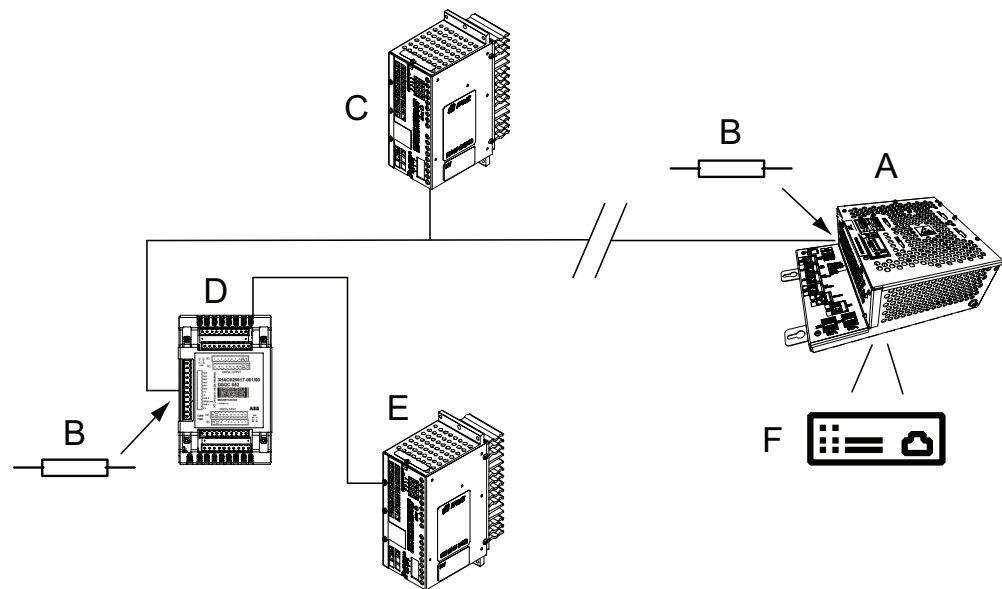

xx1900000823

A	DeviceNet anybus slave, placed in the computer module.
B	Terminating resistors (121 Ohm).
C	24 VDC power supply, for the network.
D	Distributed digital I/O device.
E	24 VDC power supply, for the I/O signals of the device.
F	

*Continues on next page*

Grounding

The following illustration shows an example of cable grounding:

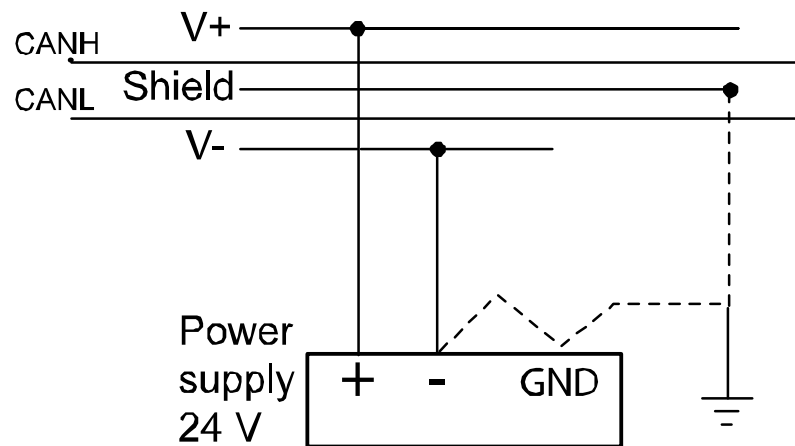

xx0300000525

## 2 Hardware overview

### 2.2.2 Termination resistors

### 2.2.2 Termination resistors

#### General

Each end of the DeviceNet network must be terminated with a 121 ohm resistor. The two terminating resistors should be as far apart as possible.

The technical specification of the termination resistor is:

- 121 ohm, 1 %, 0.25 W metal film resistor

The termination resistor is placed in the cable connector. There is no internal termination on the DeviceNet anybus slave. The termination resistor is connected between CANL and CANH - that is, between pin 2 and pin 4 according to the illustration below.

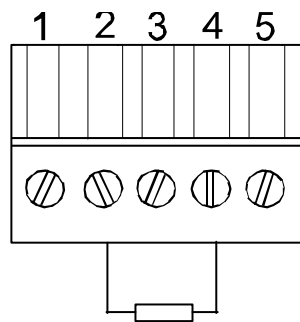

xx0400000674

#### Illustration

The illustration below shows an example of how to terminate the DeviceNet network.

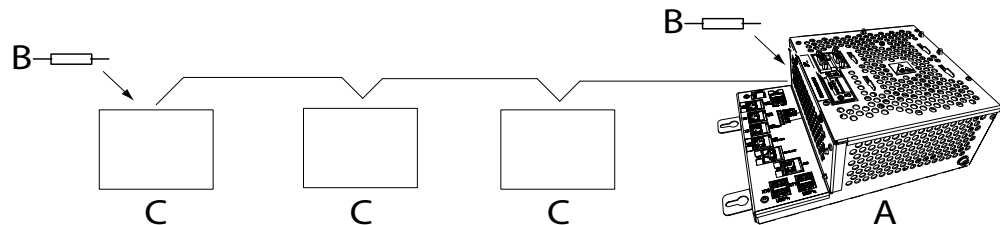

xx1300000698

A	DeviceNet anybus slave
B	Termination resistor
C	I/O device



### 2.2.3 Cabling

#### Physical connection between DeviceNet network and DeviceNet device

The following figure shows how the next DeviceNet node is connected to the DeviceNet network:

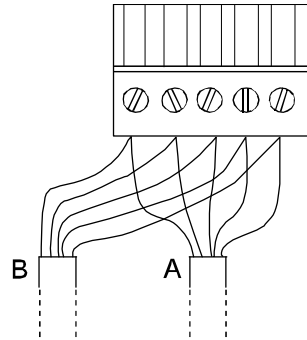

xx0400000849

A	Incoming DeviceNet network cable
B	Outgoing DeviceNet network cable

#### Illustration of trunk line and drop lines

The following figure illustrates a trunk line with drop lines. Thick or thin cable can be used for trunk lines and drop lines. For information about cable thickness and data rate, see the tables in the section [Selecting cables on page 26](#).

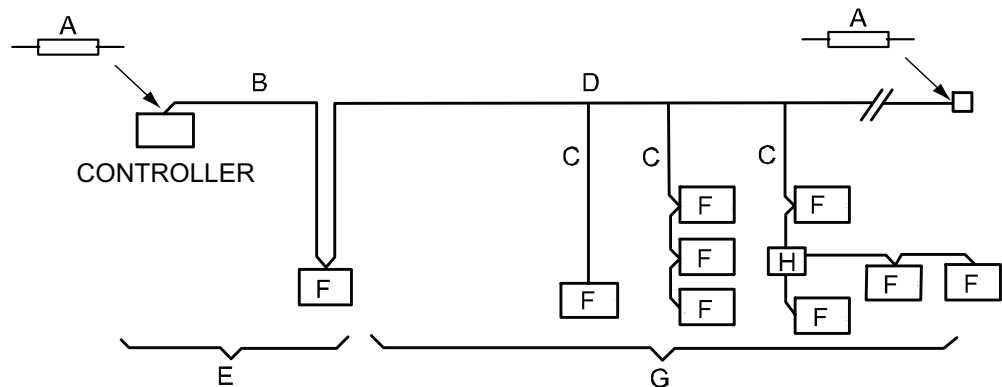

xx0300000579

A	Terminator
B	Trunk line
C	Drop line
D	Tap
E	Zero drop
F	Node
G	Short drop
H	T-connector

## 2 Hardware overview

### 2.2.4 Selecting cables

### 2.2.4 Selecting cables

#### DeviceNet network

The end-to-end network distance varies with data rate and cable thickness. For information about cable length dependency on cable type and data rate, see the following tables. For specification of the designations on the different cable types, see *ODVA DeviceNet Specification*.

#### Data rate 500 kbit/s

Cable type	Max. length
Thick trunk length	100 m (328 ft)
Thin trunk length	100 m (328 ft)
Flat trunk cable	75 m (246 ft)
Maximum drop length	6 m (20 ft)
Cumulative drop length	39 m (128 ft)

#### Data rate 250 kbit/s

Cable type	Max. length
Thick trunk length	250 m (820 ft)
Thin trunk length	100 m (328 ft)
Flat trunk cable	200 m (656 ft)
Maximum drop length	6 m (20 ft)
Cumulative drop length	78 m (256 ft)

#### Data rate 125 kbit/s

Cable type	Max. length
Thick trunk length	500 m (1,640 ft)
Thin trunk length	100 m (328 ft)
Flat trunk cable	380 m (1,250 ft)
Maximum drop length	6 m (20 ft)
Cumulative drop length	156 m (512 ft)

## 2.2.5 Repeaters

### Usage

Repeaters are used for the following purposes:

- To avoid disturbances such as ESD/EFT, which may otherwise propagate to other parts of the network.
- To isolate noisy segments.
- When using several power supplies a repeater could be used to isolate the supplies from each other to avoid voltage potential differences and ground currents.

### Extending the length of a trunk line

The following figure illustrates an application example where a repeater is used for extending the length of a trunk line:

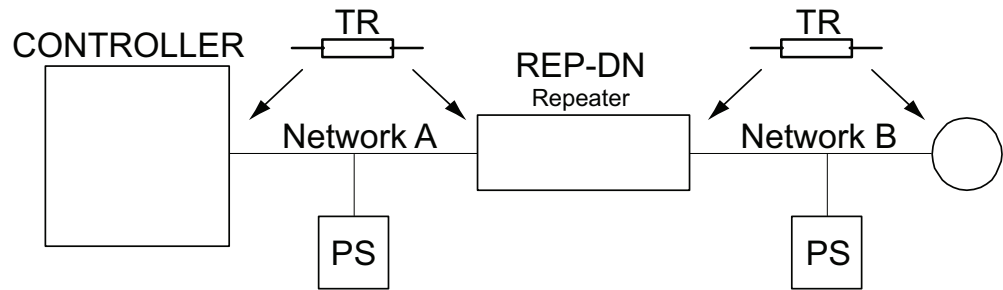

en040000724

Control	Controller
TR	Terminating resistor
PS	Power supply

*Continues on next page*

## 2 Hardware overview

### 2.2.5 Repeaters

Continued

#### Extending the length of a drop line

The following figure illustrates an application example where a repeater is used for extending the length of a drop line:

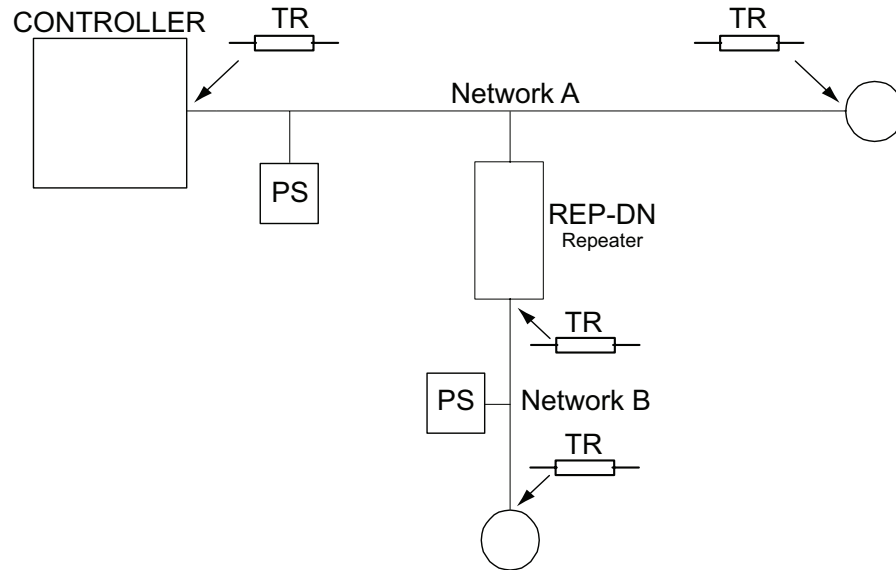

en040000725

Control	Controller
TR	Terminating resistor
PS	Power supply

## 3 Software overview

### 3.1 Information about the anybus slave device

#### General

To use the DeviceNet anybus slave device, the IRC5 controller must be installed with the option *840-4 DeviceNet Anybus Slave*.

The DeviceNet anybus slave can be used to:

- connect the IRC5 controller to a PLC.
- connect the IRC5 controller to another IRC5 controller which acts as a master.

#### Predefined network

When the robot system is installed with the DeviceNet Anybus Slave option, a predefined *Industrial Network* with the name *DeviceNet\_Anybus* is created at system startup.

#### Predefined internal anybus device

When the robot system is installed with the DeviceNet Anybus Slave option, a predefined DeviceNet internal anybus slave device with the name *DN\_Internal\_Anybus* is created with the size of 8 input bytes and 8 output bytes. If another input or output size is required, the predefined device *DN\_Internal\_Anybus* must be changed.

#### EDS file

An Electronic Data Sheet file, EDS file, is available for the anybus slave, matching the configuration of the predefined anybus internal slave device.

The EDS file, *DNET\_FA.eds*, for the anybus slave device can be obtained from the RobotStudio or the IRC5 controller.

- **In the RobotWare installation folder in RobotStudio:** ...\*RobotPackages*\*RobotWare\_RPK\_<version>*\utility\service\ioconfig\DeviceNet\
- **On the IRC5 Controller:** <SystemName>\PRODUCTS\  
<RobotWare\_xx.xx.xxxx>\utility\service\EDS\



#### Note

Navigate to the RobotWare installation folder from the RobotStudio **Add-Ins** tab, by right-clicking on the installed RobotWare version in the **Add-Ins** browser and selecting **Open Package Folder**.

#### Changing the predefined input and output sizes

If another input or output size than the predefined is used, it is recommended to edit the values in the EDS file to match the new system parameter values.

Below is an example from the EDS file where the predefined input and output sizes are changed from 8 bytes to 16 bytes:

```
[IO_Info]
Default = 0x0000;
```

*Continues on next page*

## 3 Software overview

---

### 3.1 Information about the anybus slave device

*Continued*

```
Input1 = 16;  
Output1 = 16;
```



#### Note

If the EDS file is edited, it will not be considered as a certified file.

---

#### Template I/O configuration file

A template I/O configuration file is available for the DeviceNet anybus slave device, *DN\_Internal\_Anybus*. The file contains preconfigured names for all available inputs and outputs. The file can be loaded to the controller, using RobotStudio or the FlexPendant, to facilitate and speed up the configuration.

The I/O template configuration file, *DN\_Internal\_Anybus.cfg*, can be obtained from the RobotStudio or the IRC5 controller.

- **In the RobotWare installation folder in RobotStudio:** ...\*RobotPackages*\*RobotWare\_RPK\_<version>*\utility\service\ioconfig\DeviceNet\
- **On the IRC5 Controller:** <SystemName>\PRODUCTS\  
<RobotWare\_xx.xx.xxxx>\utility\service\ioconfig\DeviceNet\



#### Note

Navigate to the RobotWare installation folder from the RobotStudio **Add-Ins** tab, by right-clicking on the installed RobotWare version in the **Add-Ins** browser and selecting **Open Package Folder**.

---

#### Limitations

The predefined DeviceNet internal anybus slave device, *DN\_Internal\_Anybus* has the following limitations:

- 8 digital input bytes and 8 digital output bytes but can be increased to the maximum value, which is 64 digital input bytes and 64 digital output bytes.
- Both the input and output map starts at bit 0 and ends at bit 63.



#### Note

If the predefined DeviceNet internal anybus slave device loses connection with the master, the configured input signals are cleared (reset to zero).

When the connection is re-established, the master updates the input signals.

## 4 Configuring the anybus slave device

### 4.1 Recommended working procedure

#### General

This section describes the recommended working procedure when installing and configuring the DeviceNet anybus slave device. The working procedure helps to understand the dependencies between the different steps.

When the IRC5 controller with the DeviceNet anybus slave device is connected to an external master, the IRC5 controller acts as an ordinary slave I/O device on the DeviceNet network.

#### Basic steps

Use this procedure to install and configure the DeviceNet anybus slave.

	Action	See
1	Create and configure the anybus slave device in the IRC5 controller using RobotStudio or FlexPendant.	<a href="#">Configuring the anybus slave device on page 32</a>
2	Configure the external master using the vendor specific configuration tool.	<a href="#">Configuring the external master on page 34</a>

#### Additional configuration

Action	See
Setting up communication between two IRC5 controllers.	<a href="#">Communication between two IRC5 controllers on page 35</a>

## 4 Configuring the anybus slave device

### 4.2 Configuring the anybus slave device

### 4.2 Configuring the anybus slave device

#### General

The anybus slave device is pre-installed at the system startup. However, the address, the input and output size of the device can be changed.

The size of the anybus slave device determines how many I/O signals that can be attached.

#### Anybus slave configuration

Use this procedure to install and configure the DeviceNet anybus slave device in the IRC5 controller, using RobotStudio.

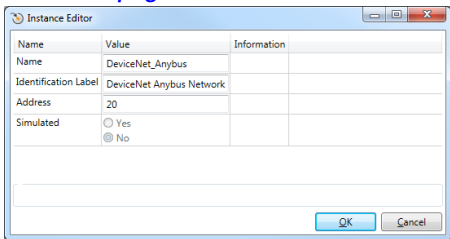
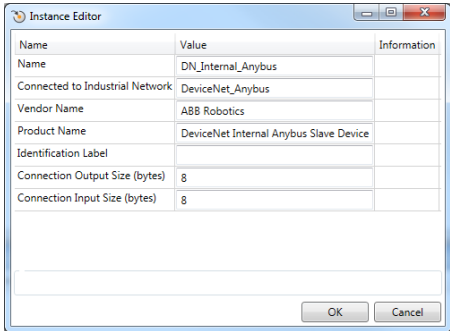
	Action	Note
1	Start RobotStudio and connect to the IRC5 controller. Request write access.	
2	Open the Configuration Editor and select I/O System.	For more information about the parameters, see <a href="#">System parameters on page 37</a> .
3	<p>If the address needs to be changed:</p> <p>In the <b>Type</b> list click <b>Industrial Network</b> and edit the network <i>DeviceNet_Anybus</i>. Edit the parameter values for the industrial network.</p> <ul style="list-style-type: none"> <li><b>Address</b>, change the default value to the desired address.</li> </ul> <p>Click <b>OK</b>.</p>	<p>This step is optional, for more information see <a href="#">Information about the anybus slave device on page 29</a>.</p>  <p>xx1400002012</p>
4	<p>If the size needs to be changed:</p> <p>In the <b>Type</b> list click <b>DeviceNet Internal Anybus Device</b> and edit the I/O device <i>DN_Internal_Anybus</i>. Edit the parameter values for the internal anybus device.</p> <ul style="list-style-type: none"> <li><b>Connection Input Size</b> and <b>Connection Output Size</b>, change the default values to the desired size.</li> </ul> <p>Click <b>OK</b>.</p>	<p>This step is optional, for more information see <a href="#">Information about the anybus slave device on page 29</a>.</p>  <p>xx1400002013</p>

Continues on next page



## 4 Configuring the anybus slave device

### 4.2 Configuring the anybus slave device

*Continued*

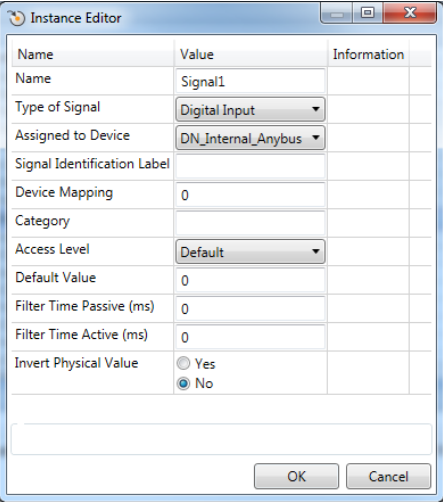
	Action	Note
5	In the <b>Type</b> list click <b>Signal</b> . Add I/O signals for the anybus slave device.	 <p>xx1400002015</p>
6	Restart the controller. Now the IRC5 controller is ready to be contacted from a DeviceNet master.	

## 4 Configuring the anybus slave device

---

### 4.3 Configuring the external master

### 4.3 Configuring the external master

---

#### General

The external master is configured using the vendor specific configuration tool that is delivered, or bought, together with the master.

The tool is used in order to specify all the I/O devices in the DeviceNet network. One of the devices is the anybus slave device of the IRC5 controller. To create such a device, the EDS file describing the internal slave device has to be imported into the vendor specific configuration tool, see [EDS file on page 29](#).

EDS files must be imported for all I/O devices used in the network.

---

#### External master configuration

This procedure describes the general steps that needs to be performed when configuring an external master, independent of which tool is used.

	Action
1	<p>Use the external master configuration tool to:</p> <ul style="list-style-type: none"><li>• Specify the address of the external DeviceNet master.</li><li>• Import the EDS files for the internal slave device and all other types of I/O devices in the network.</li><li>• Add the IRC5 controller anybus slave device and set the same DeviceNet address as in the IRC5 controller.</li><li>• Add any other I/O devices into the industrial network structure.</li><li>• Add signals for all I/O devices including the anybus slave device.</li></ul>

#### 4.4 Communication between two IRC5 controllers

##### Usage

It is possible to communicate between two IRC5 controllers using a DeviceNet anybus slave in one controller, and a DeviceNet master in the other controller.



##### Note

The DeviceNet master controller must be equipped with the option *DeviceNet Master/Slave* and the DeviceNet board DSQC1006.

For more information see *Application manual - DeviceNet Master/Slave*.

##### Illustration

The figure illustrates communication between two IRC5 controllers, using a DeviceNet anybus slave and a DeviceNet master.

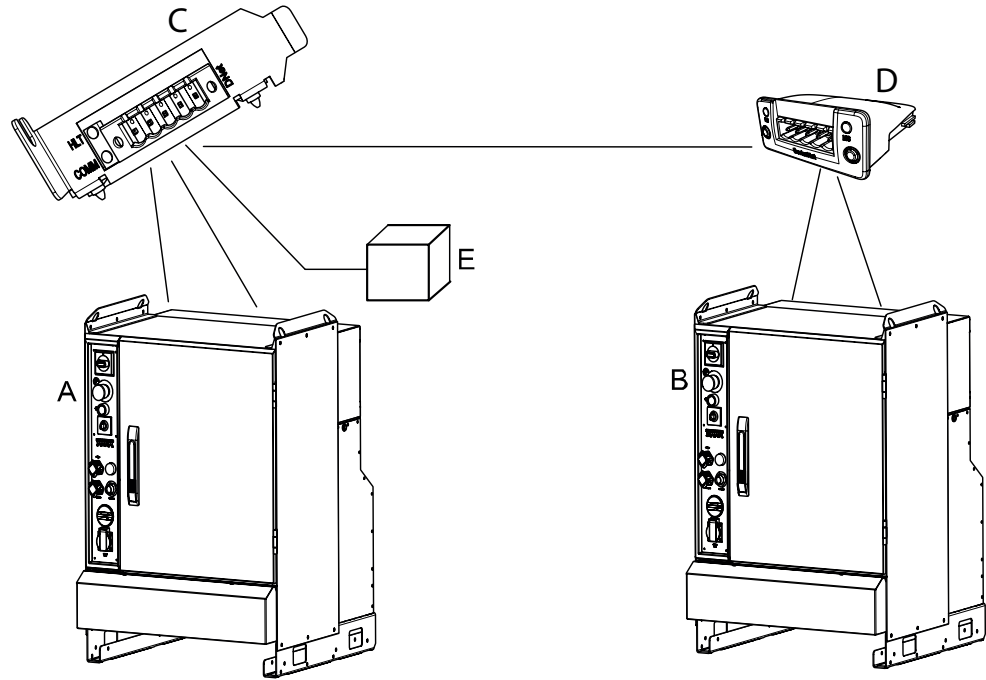

xx1300002340

A	IRC5 DeviceNet master
B	IRC5 DeviceNet slave
C	DeviceNet PCI Express board, DSQC1006
D	DeviceNet anybus slave, DSQC1004
E	Power supply unit, 24 VDC

*Continues on next page*

## 4 Configuring the anybus slave device

### 4.4 Communication between two IRC5 controllers

*Continued*

#### Configuring the master/slave controllers

The following procedure describes the configuration of a hardware setup like the one illustrated in the picture in section [Illustration on page 35](#).

	Action	Note
1	Configure the IRC5 DeviceNet internal slave device in controller B according to the configuration procedure for the anybus slave.	<a href="#">Configuring the anybus slave device on page 32</a>
2	Configure the IRC5 DeviceNet master in controller A to connect to the IRC5 DeviceNet internal slave device in controller B. Use the device template, <i>DN_Anybus</i> when adding the anybus slave device in the master controller.	See <i>Application manual - DeviceNet Master/Slave</i> .
3	Configure signals on the created devices in both controllers.	 <b>Note</b> Input signals to the <i>DN_Internal_Anybus</i> device in the slave controller (B), are configured as outputs from the <i>DN_Anybus</i> device on the master controller (A), and vice versa.
4	Physically interconnect the two IRC5 controllers.	<a href="#">Cables and connections on page 22</a>
5	Restart the slave controller.	
6	Restart the master controller.	The master will now connect to the slave controller.
7	Now it is possible to set output signals on one controller. The output signals appear as inputs on the other controller, and vice versa.	

## 5 System parameters

### 5.1 Introduction

---

#### About the system parameters

There are both DeviceNet specific parameters and more general parameters. This chapter describes all DeviceNet specific system parameters. The parameters are divided into the type that they belong to.

For information about other system parameters, see *Technical reference manual - System parameters*.

*Continues on next page*

## 5 System parameters

---

### 5.1.1 DeviceNet system parameters

#### 5.1.1 DeviceNet system parameters

---

##### Industrial Network

These parameters belong to the type *Industrial Network* in the topic *I/O System*.

Parameter	For more information, see
Name	<i>Technical reference manual - System parameters</i>
Identification Label	<i>Technical reference manual - System parameters</i>
Address	<a href="#">Address on page 39.</a>
Simulated	<i>Technical reference manual - System parameters</i>

##### DeviceNet Internal Anybus Device

These parameters belong to the type *DeviceNet Internal Anybus Device* in the topic *I/O System*.

Parameter	For more information, see
Name	<i>Technical reference manual - System parameters</i>
Connected to Industrial Network	<i>Technical reference manual - System parameters</i>
Vendor Name	<i>Technical reference manual - System parameters</i>
Product Name	<i>Technical reference manual - System parameters</i>
Identification Label	<i>Technical reference manual - System parameters</i>
Connection Input Size	<a href="#">Connection Input Size on page 40</a>
Connection Output Size	<a href="#">Connection Output Size on page 41</a>

## 5.2 Type Industrial Network

### 5.2.1 Address

---

**Description**

The parameter *Address* specifies the address of the predefined industrial network DeviceNet\_Anybus and the DeviceNet anybus slave device. This address is used by an external master to set up a connection to the anybus slave device.

---

**Usage**

This address is the address that the DeviceNet anybus slave device uses to communicate.

---

**Prerequisites**

The option *DeviceNet Anybus Slave* must be installed.

---

**Limitations**

The *Address* should not use the same address as another I/O device on the network.

---

**Default value**

The default value is 20.

---

**Allowed values**

Allowed values are the integers 0-63.

## 5 System parameters

---

### 5.3.1 Connection Input Size

## 5.3 Type DeviceNet Internal Anybus Device

### 5.3.1 Connection Input Size

---

**Parent**

*Connection Input Size* belongs to the type *DeviceNet Internal Anybus Device*, in the topic *I/O System*.

---

**Description**

The parameter *Connection Input Size* defines the data size in bytes for the input area received from the connected DeviceNet Master.

---

**Usage**

*Connection Input Size* is a DeviceNet specific parameter.

---

**Prerequisites**

The option *DeviceNet Anybus Slave* must be installed.

---

**Default value**

The default value is 8 bytes (64 signal bits).

---

**Allowed values**

Allowed values are the integers 0-64 in bytes (0-512 signal bits), specifying the input data size in bytes.



### 5.3.2 Connection Output Size

---

**Parent**

*Connection Output Size* belongs to the type *DeviceNet Internal Anybus Device*, in the topic *I/O System*.

---

**Description**

The parameter *Connection Output Size* defines the data size in bytes for the output area sent to the connected DeviceNet Master.

---

**Usage**

*Connection Output Size* is a DeviceNet specific parameter.

---

**Prerequisites**

The option *DeviceNet Anybus Slave* must be installed.

---

**Default value**

The default value is 8 bytes (64 signal bits).

---

**Allowed values**

Allowed values are the integers 0-64 in bytes (0-512 signal bits), specifying the input data size in bytes.

---

**This page is intentionally left blank**

# Index

## C

cable length, 26

## D

DeviceNet, 15  
network, 24

DeviceNet Address  
(address), 39

DeviceNet Anybus Slave, 15

DeviceNet cable, 26  
incoming, 25  
outgoing, 25

DeviceNet internal anybus slave device  
configuration, 36

DeviceNet master  
configuration, 36

DeviceNet versions, 17

drop line, 25  
extending the length, 28

## E

EDS, 15

## I

Internal anybus slave device, 13  
internal termination, 24

## L

limitations, 30

## M

master, 13  
Module Status

MS, 20

Module status LED, 20

MS, 20

## N

network security, 12

Network Status

NS, 20

Network status LED, 20

NS, 20

## P

predefined internal anybus device, 29

predefined network, 29

## R

repeaters, 27

## S

safety, 11

shield grounding, 22

slave, 13

system parameters

DeviceNet Address, 39

## T

T-connector, 25

template I/O configuration file, 30

termination resistor, 24, 27

topic I/O System

Industrial network, 29

Industrial Network, 38

Internal anybus device, 38

Internal device, 29

trunk line, 25

extending the length, 27







**ABB AB, Robotics**

**Robotics and Motion**

S-721 68 VÄSTERÅS, Sweden

Telephone +46 (0) 21 344 400

**ABB AS, Robotics**

**Robotics and Motion**

Nordlysvegen 7, N-4340 BRYNE, Norway

Box 265, N-4349 BRYNE, Norway

Telephone: +47 22 87 2000

**ABB Engineering (Shanghai) Ltd.**

Robotics and Motion

No. 4528 Kangxin Highway

PuDong District

SHANGHAI 201319, China

Telephone: +86 21 6105 6666

**ABB Inc.**

**Robotics and Motion**

1250 Brown Road

Auburn Hills, MI 48326

USA

Telephone: +1 248 391 9000

**[abb.com/robotics](http://abb.com/robotics)**